



Toll Free US & Canada: **800-645-8180**

Eastern Division

60 Fleetwood Ct., Ronkonkoma, NY 11779-6907
Telephone: (631) 471-3300 Fax: (631) 471-3308

Western Division

1219 W. Mahalo Place, Rancho Dominguez, CA 90220-5446
Telephone : (310) 632-5400 Fax: (310) 632-3900

Supplying the Aerospace, Defense & Metal Working Industries Since 1951!

Minimum Order

\$100.00 List Price

Terms

Net 30 days on approved credit only.
Approved credit cards.
Prepaid via check or wire transfer.

No C.O.D. shipments.

Returns

Return authorization is required.
Merchandise must be sent freight prepaid to the facility from which it was purchased.
A 20% restocking charge is applicable.

All claims must be made within 7 days of receipt of goods.

Freight

F.O.B. shipping point.

Special Orders

All special orders may require prepayment.

Currency

All prices are in US dollars.

Overseas Customer Terms

Same as above, only **prepayment via bank wire transfer (all fees for buyers account) or by bank check.**

US Air Tool Company (also known as USATCO) has been a family owned and operated business since 1951. We are now a US manufacturer and worldwide distributor of high quality tools for the aviation industry with offices in New York & California. In addition, from the beginning of the homebuilder era in the 1970's, USATCO has been providing tools and equipment to craftsmen around the world who build and fly their own aircraft. These "sheet-metal artists" are now flying thousands of planes built and maintained with USATCO tools.

USATCO offers the highest quality products at competitive prices, with the knowledge and experience necessary for expert advice in product selection. Our courteous staff will be pleased to assist you. And of course, all the products we offer are fully guaranteed. If you don't see what you are looking for, please don't hesitate to contact us. We work hard to provide our customers with straightforward & reliable business. Try us & see!

USATCO.com

Don't forget to check out USATCO Online, with monthly sales, homebuilder specials, surplus items & an easy to use interface its a great place to shop for tools on the web. **www.USATCO.com**

Government IMPAC Cards Accepted

USATCO Tool Repair

We repair all major brand pneumatic tools on our premises. We are an official repair station for Cherry Textron[®], Chicago Pneumatic[®], and Cooper[®] Power Tools (including Dotco[®], Gardener Denver[®], Buckeye[®] and Doler[®]). In addition, we have our own manufacturing and modification facilities. We are riveting and product assembly specialists!

We will be happy to examine your tools free of charge and give you an estimate of repair cost. Ship prepaid to any of our facilities. Please send tensiometers to our New York Lab only.

Please ask about our tool rental policy!

Limited Warranty

If for any reason you are not completely satisfied with any item purchased from us you may request a return authorization within seven (7) days of receipt of goods. When obtained, send us the item (transportation prepaid) for replacement, repair or refund. Tools manufactured by USATCO are warrantied for one (1) year from date of purchase. We cannot assume liability for abuse, misuse or alteration of goods. Any tampering with tools or attempted repairs of same will nullify this warranty. Warranties from other manufacturers available upon request.

HI-SHEAR INSTALLATION & REMOVAL

Reversible Ratchet Wrench Assemblies

For Hi-Lok®
& Hi-Light®
Fasteners

Includes
Wrench, Socket
& Hex Key



Assembly interchangeable
with Hi-Shear® assemblies.

1/4" Drive (ATHR250)		
Part Number	Socket Hex	Hex Key Size
ATHA1	3/16"	1/16"
ATHA2	7/32"	1/16"
ATHA3	1/4"	1/16"
ATHA4	9/32"	1/16"
ATHA5	5/16"	1/16"
ATHA6	11/32"	1/16"
ATHA7	7/32"	5/64"
ATHA8	1/4"	5/64"
ATHA9	9/32"	5/64"
ATHA10	5/16"	5/64"
ATHA11	11/32"	5/64"
ATHA12A	3/8"	5/64"
ATHA13	5/16"	3/32"
ATHA14	11/32"	3/32"
ATHA15A	3/8"	3/32"

3/8" Drive (ATHR375)		
Part Number	Socket Hex	Hex Key Size
ATHA16	7/16"	3/32"
ATHA21	1/2"	3/32"
ATHA17	3/8"	1/8"
ATHA18	7/16"	1/8"
ATHA22	1/2"	1/8"
ATHA19	7/16"	5/32"
ATHA20	1/2"	5/32"
ATHA23	3/8"	5/64"
ATHA24	1/2"	3/32"
ATHA25	1/2"	1/8"

1/2" Drive (ATHR500)		
Part Number	Socket Hex	Hex Key Size
ATHA26	9/16"	1/8"
ATHA27	9/16"	5/32"
ATHA28	9/16"	3/16"
ATHA29	5/8"	5/32"
ATHA30	11/16"	5/32"
ATHA31	11/16"	7/32"
ATHA32	3/4"	3/16"
ATHA33	7/8"	7/32"

3/4" Drive (ATHR750)		
Part Number	Socket Hex	Hex Key Size
ATHA34	15/16"	1/4"
ATHA35	1"	1/4"
ATHA36	1-1/8"	5/16"

Note: Assembly models ATHA23 to ATHA36 for large size collars (3 components).

Reversible Ratchet Wrenches



72 tooth spindle engages ratchet in only 5° of handle movement.

Part Number	Square Drive	Head Width	Side To Center	Head Height	Overall Length
ATHR250	1/4"	15/64"	1/4"	3/8"	5" (12.7 cm)
ATHR375	3/8"	1-1/4"	3/8"	1/2"	7" (17.8 cm)
ATHR500	1/2"	1-3/4"	1/2"	0.687"	10" (25.4 cm)
ATHR750	3/4"	2-5/8"	3/4"	1-1/8"	20" (50.8 cm)

Mini Reversible Ratchet Wrench



Compact & low profile for better maneuverability in tight areas.

Part Number	Square Drive	Head Width	Side To Center	Head Height	Overall Length
ATHR250M	1/4"	0.92"	0.46"	0.40"	4.60" (11.7 cm)

Tilting Head Reversible Ratchet Wrench



Tilting head is perfect for maneuvering in limited access areas.

Part Number	Square Drive	Head Width	Side To Center	Head Height	Overall Length
ATHR-TILT	1/4"	0.90"	0.45"	0.40"	6-1/4" (15.9 cm)

Double Box Ratchet Wrenches



- Perfect for installing Hi-Lok® fasteners in tight areas.
- Shoulder ring prevents collar from slipping through the socket.
- Optional ejector pin quickly discards removed collar.

Note: All tools are 3/8" thick except ATBR-2125E (5/16" thick).

Standard Models				
Straight	25° Offset	Hex #1	Hex #2	Overall Length
ATBR-2125	ATBRO-2125	7/32"	1/4"	4-3/32" (104 mm)
ATBR-2528	ATBRO-2528	1/4"	9/32"	4-3/32" (104 mm)
ATBR-3134	ATBRO-3134	5/16"	11/32"	4-3/32" (104 mm)
ATBR-3137	ATBRO-3137	5/16"	3/8"	5-7/32" (133 mm)
ATBR-4350	ATBRO-4350	7/16"	1/2"	5-7/32" (133 mm)

Ejector Models				
Straight	25° Offset	Hex #1	Hex #2	Overall Length
ATBR-2125E	ATBRO-2125E	7/32"	1/4"	4-3/32" (104 mm)
ATBR-2528E	ATBRO-2528E	1/4"	9/32"	4-3/32" (104 mm)
ATBR-3134E	ATBRO-3134E	5/16"	11/32"	4-3/32" (104 mm)
ATBR-3137E	ATBRO-3137E	5/16"	3/8"	5-7/32" (133 mm)
ATBR-4350E	ATBRO-4350E	7/16"	1/2"	5-7/32" (133 mm)

'Tight Squeeze' Installation Tool Assemblies

Single-Handed Operation



- Newly designed, full function Hi-Lok® and Hi-Lite® installation tool.
- Unique profile for operation in tight spots and around corners.
- Toothless ratcheting system for quick tool engagement.
- Interchangeable hex keys and sockets fit an entire range of pin/collar combinations.

Part Number	Socket Size	Hex Key Size
TSQ25-218-062	7/32"	1/16"
TSQ25-250-062	1/4"	1/16"
TSQ25-281-062	9/32"	1/16"
TSQ25-312-062	5/16"	1/16"
TSQ25-281-078	9/32"	5/64"
TSQ25-312-078	5/16"	5/64"
TSQ25-343-078	11/32"	5/64"
TSQ25-437-078	7/16"	5/64"
TSQ25-312-094	5/16"	3/32"
TSQ25-343-094	11/32"	3/32"
TSQ25-437-094	7/16"	3/32"
TSQ25*	—	—

* Tool only - applicable sockets shown on right and 'Tight Squeeze' hex keys below.



Replacement 'Tight Squeeze' Hex Keys	
Part Number	Key Size
TSQ062	1/16"
TSQ078	5/64"
TSQ094	3/32"

Roller Ratchet Installation Tools

Single Head Type



Quick Ratchet Engagement

- Ideal for installing Hi-Lok® & other fasteners in confined areas.
- Uses standard drive sockets & Hi-Shear® style set screw sockets.
- Allen wrench through hole for Hi-Lock® & Hi-Lite® pins.

1/4" Square Drive			
Part Number	Max. Torque	Head Height	Overall Length
RR40S-SP	150 in-lbs	0.91"	3-1/2" (89 mm)
RR40SP	150 in-lbs	0.91"	6" (152 mm)
RR80	200 in-lbs	1.37"	6" (152 mm)
RR130	250 in-lbs	0.92"	7" (178 mm)

3/8" Square Drive			
Part Number	Max. Torque	Head Height	Overall Length
RR250	400 in-lbs	1.21"	8" (203 mm)
RR400	600 in-lbs	1.21"	9" (229 mm)

Hi-Lok® & Hi-Lite® Installation Sockets

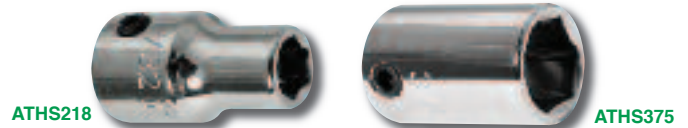

- For the installation of Hi-Lok® & Hi-Lite® fasteners.
- Anti-FOD set screw provides positive square drive engagement.

1/4" Drive Socket		3/8" Drive Socket		1/2" Drive Socket	
Part No.	Hex	Part No.	Hex	Part No.	Hex
ATHS187	3/16"	ATHS375	3/8"	ATHS562	9/16"
ATHS218	7/32"	ATHS437	7/16"	ATHS625	5/8"
ATHS250	1/4"	ATHS500	1/2"	ATHS687	11/16"
ATHS281	9/32"			ATHS750	3/4"
ATHS312	5/16"			ATHS875	7/8"
ATHS343	11/32"				
ATHS375A	3/8"				
3/4" Drive Socket					
Part No.	Hex				
ATHS937	15/16"				
ATHS1000	1"				
ATHS1125	1-1/8"				

Handi-Hex® Drivers



- General use & production assembly using socket screw products.
- Includes adjustable, replaceable allen bit & bit change key.
- Replacement blades available, please inquire.

Part Number	Key Size	Part Number	Key Size
57400	.028"	57410	3/32"
57402	.035"	57412	7/64"
57404	.050"	57414	1/8"
57406	1/16"	57416	9/64"
57408	5/64"		

HI-SHEAR INSTALLATION & REMOVAL

'Savi-Socket' Collar Removal Sockets



*High Strength,
Heat-Treated
Tool Steel*

*Corrosion
Resistant Coating*

SAVI-56

- New conical/tapered shape with helical teeth to quickly remove Hi-Lok®, Hi-Lite®, Eddie Bolt® and Huck® threaded collars.
- Socket is firmly drawn onto the collar, removing it with minimal wear and effort - all without jamming the collar into the socket.
- For use on aluminum, steel, titanium and all coated collars.
- Anti-FOD set screw for positive retention. Made in the USA.

1/4" Square Drive			
Part Number	Nominal Collar Size	Collar 'Dash' Number	Top Of Collar Diameter*
SAVI-21	5/32" EB	5 EB	0.21" (5.5 mm)
SAVI-24	5/32", 3/16" EB	5, 6 EB	0.24" (6.2 mm)
SAVI-25	5/32"	5	0.25" (6.5 mm)
SAVI-26	5/32", 3/16"	5, 6	0.26" (6.7 mm)
SAVI-27	5/32", 3/16"	5, 6	0.27" (7.0 mm)
SAVI-28	3/16"	6	0.28" (7.2 mm)
SAVI-29	3/16"	6	0.29" (7.5 mm)
SAVI-32	1/4", 1/4" EB	8, 8 EB	0.32" (8.2 mm)
SAVI-33	1/4"	8	0.33" (8.5 mm)
SAVI-34	1/4"	8	0.34" (8.7 mm)
SAVI-35	1/4"	8	0.35" (9.0 mm)
SAVI-36	1/4"	8	0.36" (9.2 mm)
SAVI-37	1/4"	8	0.37" (9.5 mm)
SAVI-39	5/16" EB	10 EB	0.39" (10.0 mm)

3/8" Square Drive			
Part Number	Nominal Collar Size	Collar 'Dash' Number	Top Of Collar Diameter*
SAVI-43	5/16"	10	0.43" (11.0 mm)
SAVI-45	5/16"	10	0.45" (11.5 mm)
SAVI-47	5/16"	10	0.47" (12.0 mm)
SAVI-50	5/16"	10	0.50" (12.7 mm)
SAVI-51	3/8"	12	0.51" (13.0 mm)
SAVI-55	3/8"	12	0.55" (14.0 mm)
SAVI-56	3/8"	12	0.56" (14.3 mm)
SAVI-59	7/16"	14	0.59" (15.0 mm)
SAVI-63	7/16"	14	0.63" (16.0 mm)

1/2" Square Drive			
Part Number	Nominal Collar Size	Collar 'Dash' Number	Top Of Collar Diameter*
SAVI-67	1/2"	16	0.67" (17.0 mm)
SAVI-69	1/2"	16	0.69" (17.5 mm)

* Collar opening diameter where socket just fits over the top of the collar.

'Savi-Socket' Collar Removal Socket Sets



SAVI-568-RED

*Convenient Sets
Contain The Most
Popular Sizes*

4PC Eddie Bolt® Set - 1/4" Square Drive		
Part Number	Included Sockets*	Dash Size
SAVI-56810-EB	SAVI-21, 24, 32 & 39	-5, -6, -8 & -10

12PC Hi-Lok® & Hi-Lite® Set - 1/4" Square Drive		
Part Number	Included Sockets*	Dash Size
SAVI-568-HL	SAVI-24 to 29 & SAVI-32 to 37	-5, -6 & -8

6PC Hi-Lok® Set - 1/4" Square Drive		
Part Number	Included Sockets*	Dash Size
SAVI-568-RED	SAVI-25, 26, 28, 29, 36 & 37	-5, -6 & -8

6PC Hi-Lok® & Hi-Lite® Large Size Set - 3/8" Square Drive		
Part Number	Included Sockets*	Dash Size
SAVI-1012	SAVI-43, 45, 50, 51, 55 & 56	-10 & -12

* Reference chart on left for individual collar specifications.

Hi-Lok® Collar Removal Sockets

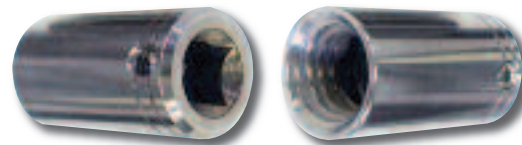

- Patented design efficiently removes Hi-Lok® & Eddie-Bolt® collars.
- Tough 17-4 tool steel, heat treated for high wear resistance.
- Best suited for use on aluminum collars.

1/4" Square Drive		
Part Number	Pin Dash	Collar Size
3581-5/32	-5	5/32"
3581-3/16	-6	3/16"
3581-1/4	-8	1/4"
3581-5/16	-10	5/16"
3581-3/8	-12	3/8"
3581-7/16	-14	7/16"

Part Number	Description
53-3581	Set of 4 (-5, -6, -8 & -10)

Hi-Lok® & Eddie-Bolt® Collar Removal Sockets

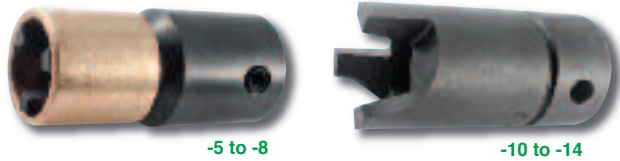

- Driven with hand or pneumatic tools with a 3/8" square drive.
- Sockets 'bite' into the collar allowing it to be unscrewed.

Part Number	Nominal Pin Diameter	Part Number	Nominal Pin Diameter
02-HLC1-5	5/32"	02-HLC1-10	5/16"
02-HLC1-6	3/16"	02-HLC1-12	3/8"
02-HLC1-8	1/4"	02-HLC1-14	7/16"

Note: -8 requires initial plier loosening prior to removal, (pliers available on next page).

Hi-Shear® Six-Wing Collar Removal Assemblies

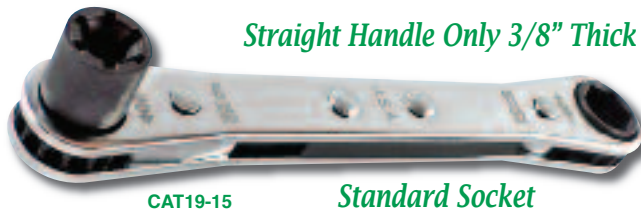

- Tapered splines developed specifically for six-wing collars.
- Removes collar while preventing collar re-use or re-installation.
- Assemblies include box ratchet handle and drive socket.

Standard Socket, 4-1/4" Overall Length					
Complete Assembly	Socket Only	Pin Dash	Pin Size	Socket Length	Socket Dia.
CAT19-15	CAT18-15	-5	5/32"	1/2"	.35"
CAT19-18	CAT18-18	-6	3/16"	1/2"	.35"
CAT19-25	CAT18-25	-8	1/4"	1/2"	.47"

K-Fast® 8-Spline Installation & Removal Sockets

Tamper Proof

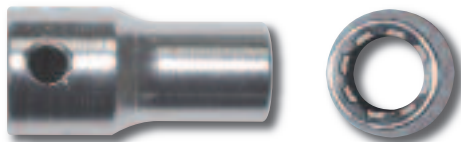

- Uses standard square drive ratchet wrenches.
- For Kaynar KFN fasteners (Airbus aircraft, A10 Thunderbolt etc.).

1/4" Square Drive	
Part Number	Size
ATSK3686-2T	#8
ATSK3686-3T	#10
ATSK3686-4T	1/4"

3/8" Square Drive	
Part Number	Size
ATSK3686-5F	5/16"
ATSK3686-6F	3/8"

1/2" Square Drive	
Part Number	Size
ATSK3686-7S	7/16"
ATSK3686-8S	1/2"
ATSK3686-9S	9/16"
ATSK3686-10S	5/8"

Hi-Lok® Fastener Ratchet Extensions

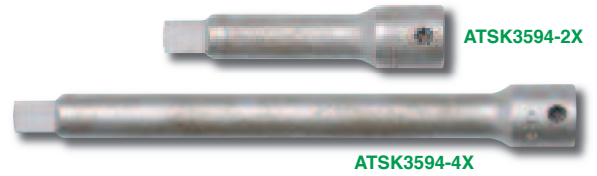

- Continuous through-hole for hex key insertion.
- Set screw secures extension to ratchet.

Part Number	Drive	Overall Length
ATSK3594-2X	1/4"	2" (51 mm)
ATSK3595-3X	3/8"	3" (76 mm)

Part Number	Drive	Overall Length
ATSK3594-4X	1/4"	4" (102 mm)
ATSK3595-6X	3/8"	6" (152 mm)

Frangible Collar Hand Removal Tools



- Slips down over Hi-Lok® or similar collar and gently unscrews.
- Clean removal in limited access areas with no cutting or prying.

Part Number	Pin Dash Number	Nominal Pin Dia.	Head Width	Overall Length
REM100-56	-5	5/32"	.42"	5.6" (142 mm)
	-6	3/16"	.42"	
REM100-8	-8	1/4"	.55"	5.8" (147 mm)
REM100-10	-10	5/16"	.67"	6.9" (175 mm)
REM100-12	-12	3/8"	.75"	7.9" (200 mm)
REM100-14	-14	7/16"	.95"	9.9" (251 mm)

Thd. Shank Huck® & Hi-Shear® Collar Removers

Four-Flute H.S.S.

- Cleanly cuts off the swaged collar of Huck® & Hi-Shear® type fasteners.
- Internal stop prevents contact with the work surface.



Note: 1/4"-28 thread. For use with microstop countersink cages.

Part Number	Fastener Size	Overall Dia.
02-86-0	3/32" HS47	.365"
02-86-1	1/8" HS47	.365"
02-86-2	5/32" HS47	.365"
02-86-3	3/16" HS47	.438"
02-86-4	1/4" HS47	.500"
02-86-5	5/16" HS47	.562"
02-86-6	3/8" HS47	.625"

Part Number	Fastener Size	Overall Dia.
02-87-1	3/16" L6	.323"
02-87-2	1/4" L8	.413"
02-87-3	1/4" OS8	.372"
02-87-4	5/16" L10	.528"
02-87-5	5/16" OS10	.465"
02-87-6	3/8" L12	.622"
02-87-7	3/8" OS12	.465"

HI-SHEAR INSTALLATION & REMOVAL

Hi-Lok® & Hi-Tique® Collar Removal Assemblies



HLH128-8

Great For Limited Access Areas

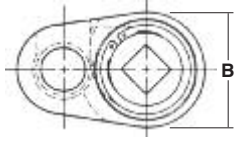

-6 & -8 Configuration

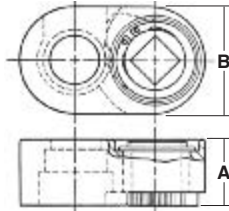

-10 To -16 Configuration

1/4" Square Drive				
Part Number	Size	'A' Height	'B' Width	Overall Length
HLH128-6	3/16"	0.400"	0.800"	1.2" (30.4 mm)
HLH128-8	1/4"	0.400"	0.800"	1.3" (33.0 mm)
HLH128-10	5/16"	0.500"	0.800"	1.4" (35.5 mm)

3/8" Square Drive				
Part Number	Size	'A' Height	'B' Width	Overall Length
HLH128-12	3/8"	0.562"	1.070"	1.7" (43.1 mm)
HLH128-14	7/16"	0.687"	1.150"	1.9" (48.2 mm)
HLH128-16	1/2"	0.687"	1.200"	2.1" (53.3 mm)

Hi-Lok® & Hi-Tique® Collar Removal Tool Kit



Provides close quarter tools to remove Hi-Lok® & Hi-Tique® collars.

Kit Includes:

Six Collar Removal Tools (3/16", 1/4", 5/16", 3/8", 7/16" & 1/2"), Two 1/4" Drive Flex Handles (-6, -8, -10 & -12, -14, -16), Two 1/4" Drive Extensions (-6, -8, -10 & -12, -14, -16), Parts List & Steel Fitted Carrying Case

Part Number	Description
HLK10	Complete 12 PC Kit

DK Series Hi-Lok® & Hi-Lite® Collar Rem. Tools



Great For Limited Access Areas

Remove Hi-Lok® & Hi-Lite® collars with or without captive washers.

Part No.	Collar Dia. Range
DK1-1	.239" to .262"
DK1-3	.269" to .290"
DK2-4	.332" to .350"
DK2-5	.370"

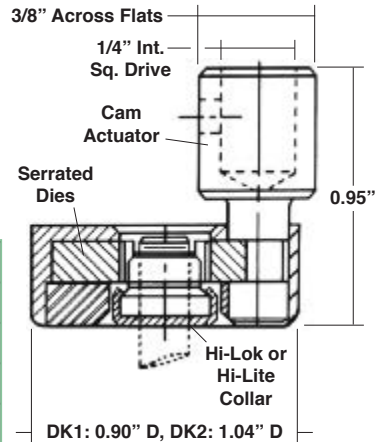

Note: Use with 1/4" male square drive or 3/8" open end wrench (not included).

Hi-Lok® Collar Removal Pliers



Hardened & Tapered Head

Diamond cut jaws for a patterned grip on fasteners from any angle.

Part Number	Capacity	Overall Length
04-3579	Up to 5/16"	7-3/8" (187 mm)

Hi-Lok® Collar Removal Pliers

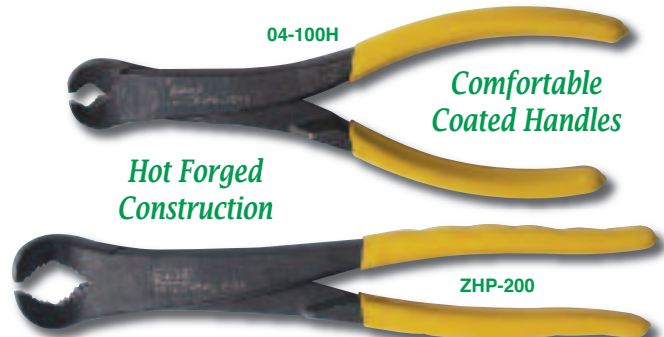

04-100H

Comfortable Coated Handles

Hot Forged Construction



ZHP-200

- Quick & inexpensive alternative for removing frangible hex collars such as Hi-Lok®, Hi-Lite®, Hi-Tique®, Veri-Lite® and C-Lok®.
- Hardened steel jaws designed to maximize gripping surface.



ZHP-200B

NEW Ergonomic Offset Pliers

- Ergonomic design with a 42° offset for better leverage.

Part Number	Style	Capacity	Overall Length
04-100H	Standard	5/32", 3/16", 1/4" & 5/16"	7-3/8" (187 mm)
ZHP-100B	Offset		6-1/2" (165 mm)
ZHP-200	Standard	5/16", 5/8" & 3/4"	9" (229 mm)
ZHP-200B	Offset		8-1/4" (210 mm)

Pin Protrusion Gauges



Part Number	Type	Included Sizes
2-1522	Hi-Lok® Standard	-5, -6, -8, -10 & -12
2-1522HST	Hi-Lite® Standard	
2-1522-B	Hi-Lok® Aerospace 'B'	
2-1522HST-B	Hi-Lite® Aerospace 'B'	
2-1522HLM	Hi-Lok® / Hi-Tigue® Metric	4, 5, 6, 8, 10 & 12 mm
2-1522HSTM	Hi-Lite® Metric	
2-1522-B-2	Hi-Lok® Large Diameter	-14, -16, -18, -20 & -24
2-1522HST-2	Hi-Lite® Large Diameter	

Grip Gauges

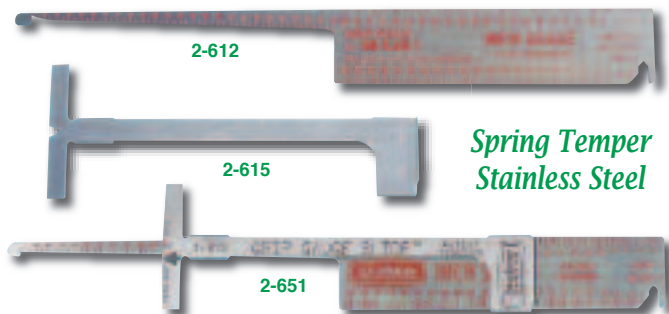

Part No.	Description
2-612	1/16" Increments To 3", 1 mm Increments To 75 mm
2-615	Grip Gauge Slide (for 2-612 above)
2-651	Grip Gauge Assembly (includes 2-612 & 2-615 above)

Grip Gauges

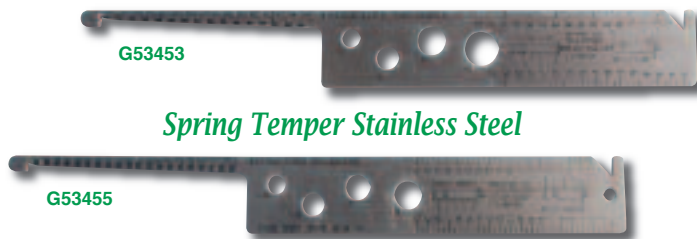

Part Number	Description
G53453	For Visu-Lok® Jo-Bolt® Fasteners
G53455	For Composi-Lok® Fasteners

Rivet Stem Shaver



- Unique tool shaves corebolt breakoffs on Composi-Lok® & Visu-Lok® fasteners with a swift, 30,000 RPM 'slicing' action.
- Precision setup with new depth adjustment gauge.
- Long lasting abrasive cutting discs for smooth, uninterrupted cuts.

Rivet Stem Shaver	Replacement Cutting Disc	Free RPM	Depth Adj.	Weight
MAPS-01	MAPSD-01	30,000	0.001"	1.25 lbs (0.6 kgs)

Reversible Ratchet Wrench Installation Kit



- Install Hi-Lite®, Hi-Lok® & Hi-Tigue® pin and collar combinations.
- Includes all of the tools listed below with a steel carrying case.

Part Number	Description
HLK14	Complete 32 PC Kit

Reversible Ratchet Wrench Assemblies		
Part Number	Socket Hex	Wrench Tip Hex
ATHA5	5/16"	1/16"
ATHA10	5/16"	5/64"
ATHA11	11/32"	5/64"
ATHA14	11/32"	3/32"
ATHA16	7/16"	3/32"
ATHA18	7/16"	1/8"
ATHA20	1/2"	5/32"
ATHA28	9/16"	3/16"
ATHA31	11/16"	7/32"

Double Box Ratchet Wrench Assemblies		Gauges	
Part Number	Socket Hex	Part No.	Type
ATBR-3134	5/16" & 11/32"	2-1522	Protrusion
ATBR-4350	7/16" & 1/2"	2-612	Grip

HI-SHEAR INSTALLATION & REMOVAL

Hi-Lok® Installation & Removal Kits



Deluxe Ratchet & Socket Kit:

ATI3600K

1/4" & 3/8" Drive Reversible Ratchets, Ten Sockets (3/16", 7/32", 1/4", 9/32", 5/16", 11/32", 3/8", 7/16" & 1/2"), 1/16" Hex Key, Four T-Hex Keys (5/64", 3/32", 1/8" & 5/32"), Two Extensions (2" & 3") & Fitted Plastic Case

Part Number	Description
ATI3600K	Complete 20 PC Kit



Ratchet & Socket Kit:

ATI3594K

1/4" Drive Reversible Ratchet, Seven Sockets (3/16", 7/32", 1/4", 9/32", 5/16", 11/32" & 3/8"), Two Extensions (2" & 4"), 1/16" Hex Key, Two T-Hex Keys (5/64" & 3/32") & Fitted Plastic Case

Part Number	Description
ATI3594K	Complete 14 PC Kit

Hi-Lok® Installation & Removal Kits (cont'd)



Roller Clutch Ratchet Kit:

ATISK3539A8

1/4" Drive Installation Wrench, Four Hex Installation Wrenches (7/32", 1/4", 5/16" & 11/32"), Diamond Cut Removal Pliers & Fitted Plastic Case

Part Number	Description
ATISK3539A5	Complete 7 PC Kit

Deluxe Roller Clutch Ratchet Kit:

Two 1/4" Drive Wrenches (1 installation, 1 removal), Six Hex Installation Wrenches (7/32", 1/4", 5/16", 11/32", 3/8" & 7/16"), Diamond Cut Removal Pliers & Fitted Plastic Case

Part Number	Description
ATISK3539A8	Complete 6 PC Kit

Other Tool Kits Available, Please Inquire

'Liberator' Ratchet Set



Includes Fitted Plastic Case

- 90° & 360° ratchet heads are great for confined spaces.
- Various length handles accept 1/4"-28 bits & countersinks.
- Threaded 1/4" drive socket adapter for multi-function ratchet use.

Part Number	Description
70978	Complete 12 PC Kit

Hi-Lok® Pneumatic Installation & Removal Kit



Kit includes:

HLKT2000

Pneumatic 1/4" Square Drive Ratchet (with through hole), Nine Hi-Lok® Sockets (5/32", 3/16", 7/32", 1/4", 9/32", 5/16", 11/32", 3/8" & 7/16"), Four Hi-Lok® Collar Removal Sockets (5/32", 3/16", 1/4" & 5/16") Three Hex Keys (1/16", 5/64" & 3/32") & Fitted Plastic Case

Part Number	Description
HLKT2000	Complete 18 PC Kit

USATCO Tool Repair

USATCO has been repairing tools for over 60 years. Send your inoperable tool to our state of the art facility (NY or CA) for a free estimate!

Jo-Bolt® & Visu-Lok® Installation Hand Tools



Standard Series

Standard Ratchet Hand Tools (includes driver assembly)				
Part No. Flush	Part No. Protruding	Part No. Millable	Part No. Reduced Flush	Driver Assembly
HWF165	HWP165	HWA165	HWT165	-5 (5/32")
HWF200	HWP200	HWA200	HWT200	-6 (3/16")
HWF260	HWP260	HWA260	HWT260	-8 (1/4")
HWF312	HWP312	—	HWT312	-10 (5/16")
HWF375	HWP375	—	HWT375	-12 (3/8")



Close Quarter Series

Close Quarter Ratchet Hand Tools (includes driver assembly)				
Part No. Flush	Part No. Protruding	Part No. Millable	Part No. Reduced Flush	Driver Assembly
HWF5	HWP5	HWA5	HWT5	-5 (5/32")
HWF6	HWP6	HWA6	HWT6	-6 (3/16")
HWF8	HWP8	HWA8	HWT8	-8 (1/4")
HWF10	HWP10	—	HWT10	-10 (5/16")
HWF12	HWP12	—	HWT12	-12 (3/8")

Pneumatic Installation Tools For Jo-Bolt®, Visu-Lok® & Composi-Lok® Fasteners

Specifically designed for the installation of 5/32" to 3/8" Jo-Bolt®, Visu-Lok®, Visu-Lok II®, Composi-Lok® & Composi-Lok II® blind bolts.

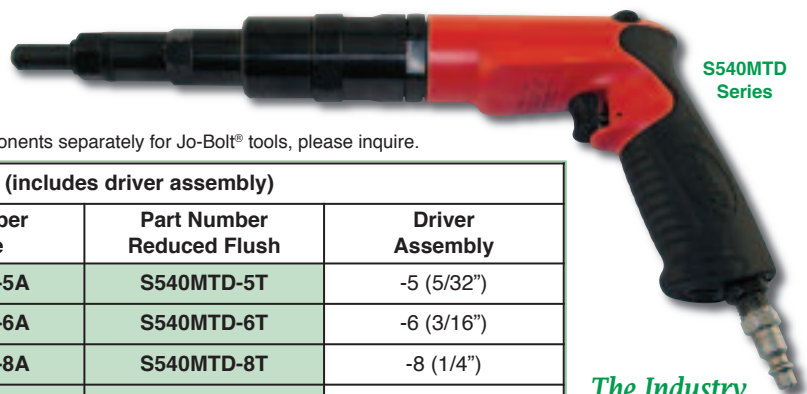

S540MTD Series

The Industry Standard

Note: For more detailed information and/or assistance in ordering any components separately for Jo-Bolt® tools, please inquire.

Pistol Grip Master Torque Drivers (includes driver assembly)				
Part Number Flush	Part Number Protruding	Part Number Millable	Part Number Reduced Flush	Driver Assembly
S540MTD-5	S540MTD-5P	S540MTD-5A	S540MTD-5T	-5 (5/32")
S540MTD-6	S540MTD-6P	S540MTD-6A	S540MTD-6T	-6 (3/16")
S540MTD-8	S540MTD-8P	S540MTD-8A	S540MTD-8T	-8 (1/4")
S540MTD-10	S540MTD-10P	S540MTD-10A	S540MTD-10T	-10 (5/16")
S540MTD-12	S540MTD-12P	S540MTD-12A	S540MTD-12T	-12 (3/8")

Lever Grip Torque Responsive Adapters (includes driver ass'y)				
Part No. Flush	Part No. Protruding	Part No. Millable	Part No. Reduced Flush	Driver Assembly
7440M-5	7440M-5P	7440M-5A	7440M-5T	-5 (5/32")
7440M-6	7440M-6P	7440M-6A	7440M-6T	-6 (3/16")
7440M-8	7440M-8P	7440M-8A	7440M-8T	-8 (1/4")

Lever Grip Close Quarter Tools (includes driver assembly)				
Part No. Flush	Part No. Protruding	Part No. Millable	Part No. Reduced Flush	Driver Assembly
7440C-5	7440C-5P	7440C-5A	7440C-5T	-5 (5/32")
7440C-6	7440C-6P	7440C-6A	7440C-6T	-6 (3/16")
7440C-8	7440C-8P	7440C-8A	7440C-8T	-8 (1/4")

Visu-Lok® Tool Kits



Visu-Lok® Ratchet Hand Tool Kit:

HW300 Ratchet Hand Tool, Fastener Drivers (-5, -6, -8, -10 & -12), Flush Nose (-5, -6, -8, -10 & -12), Protruding Nose (-5, -6, -8, -10 & -12), Millable Nose (-5, -6 & -8), Reduced Flush Nose (-5, -6, -8, -10 & -12), Visu-Lok® Grip Gauge & Tool Box

Part Number	Description
4000KIT	Complete 26 PC Kit

Visu-Lok® Right Angle Torque Responsive Kit:

7440M Complete Driver Assembly, Fastener Drivers (-5, -6 & -8), Flush Nose (-5, -6 & -8), Protruding Nose (-5, -6 & -8), Millable Nose (-5, -6 & -8), Reduced Flush Nose (-5, -6 & -8), Visu-Lok® Grip Gauge & Tool Box

Part Number	Description
4070KIT	Complete 18 PC Kit

Visu-Lok® Pistol Grip Master Torque Driver Kit:

S540MTD Pneumatic Motor, PT Nose (flush & protruding), Flush Nose (-5, -6, -8 & -10), Protruding Nose (-5, -6 & -8), Millable Nose (-5, -6, -8 & -10), Visu-Lok® Grip Gauge & Tool Box

Part Number	Description
4090KIT	Complete 16 PC Kit

Visu-Lok® Flush & Protruding Ratchet Hand Tool Kit:

HW300 Ratchet Hand Tool, HW100 & HW400 Close Quarter Tools, Fastener Drivers (-5, -6, -8 & -10), Flush Nose (-5, -6, -8 & -10), Protruding Nose (-5, -6, -8 & -10), Close Quarter Flush Nose (-5, -6, -8 & -10), Close Quarter Protruding Nose (-5, -6, -8 & -10), Close Quarter Millable Nose (-5, -6, -8 & -10) & Visu-Lok® Grip Gauge

Part Number	Description
VLHK-101	Complete 28 PC Kit

Visu-Lok® Flush & Protruding Ratchet Hand Tool Kit:

HW300 Ratchet Hand Tool, Fastener Drivers (-5, -6 & -8), Flush Nose (-5, -6 & -8), Protruding Nose (-5, -6 & -8) & Visu-Lok® Grip Gauge

Part Number	Description
VLHK-102	Complete 11 PC Kit

Composi-Lok® Tool Kits

Convenient & Versatile

4060KIT



Composi-Lok® Right Angle Master Torque Driver Ass'y Kit:

7440M-BF Complete Driver Assembly, MTD502-BF Master Torque Driver, Fastener Drivers (-5, -6 & -8), Flush Nose (-5, -6 & -8), Protruding Nose (-5, -6 & -8), Reduced Flush Nose (-5, -6 & -8), Composi-Lok® Grip Gauge & Tool Box

Part Number	Description
4060KIT	Complete 16 PC Kit

Composi-Lok® Pistol Grip Master Torque Driver Kit:

S540MTD-BF Pneumatic Motor, Fastener Drivers (-5, -6, -8, -10 & -12), Flush Nose (-5, -6, -8, -10 & -12), Protruding Nose (-5, -6, -8, -10 & -12), Reduced Flush Nose (-5, -6, -8, -10 & -12), Two Composi-Lok® Grip Gauges & Tool Box

Part Number	Description
4080KIT	Complete 24 PC Kit

Composi-Lok® Ratchet Hand Tool Kit:

HW300 Ratchet Hand Tool, HW100 & HW400 Close Quarter Tools, Fastener Drivers (-5, -6, -8 & -10), Protruding Wrench Adapters (-7 & -8), Flush Nose (-5, -6, -7, -8, -9 & -10), Protruding Nose (-5, -6, -7, -8, -9 & -10), Close Quarter Fastener Drivers (-5, -6, -7, -8, -9 & -10), Close Quarter Flush Nose (-5, -6, -7, -8, -9 & -10), Close Quarter Protruding Nose (-5, -6, -7, -8, -9 & -10) & Two Composi-Lok® Grip Gauges

Part Number	Description
CLHK-101	Complete 41 PC Kit

Composi-Lok® Ratchet Hand Tool Kit:

HW300 Ratchet Hand Tool, HW100 & HW400 Close Quarter Tools, Wrench Adapters (-5, -6, -7, -8 & -10), Three Universal Nose Tips (for -5 to -12), Three Nose Tip Connectors (for -5 to -12), Close Quarter Wrench Adapters (-5, -6, -7, -8 & -10), Three Close Quarter Nose Tip Connectors (for -5 to -12) & Two Composi-Lok® Grip Gauges

Part Number	Description
CLIIHK-101	Complete 24 PC Kit

Hi-Shear® Pistol Grip Pneumatic Inst. Tooling



*Straight Driver Assembly
With Extended Socket And
Super Key (T-Series)*



*Offset Mini Driver Assembly
With Thin Flush Socket And
Super Key (T-Series)*

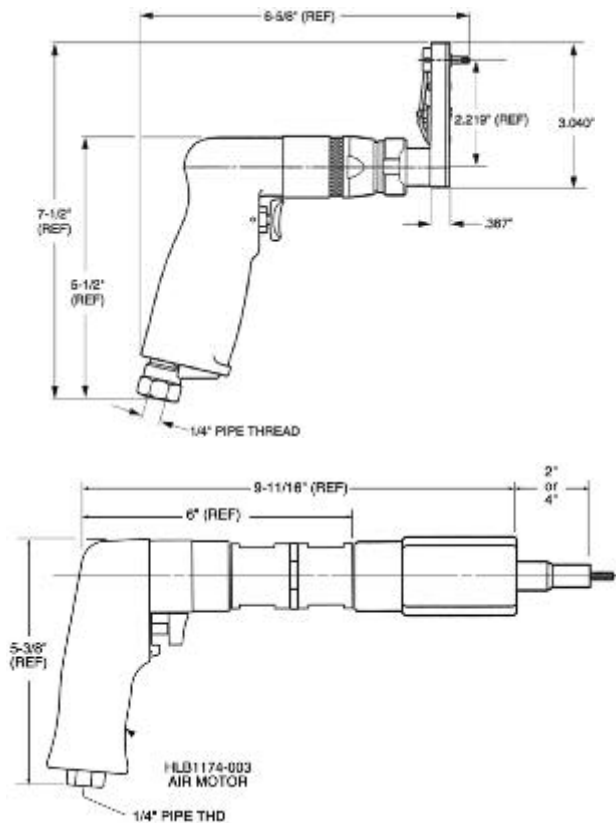

Specifications		
Tool	HLA1201	HLA1501
Operating Pressure	90 PSIA	90 PSIA
Max. Torque Rating	60 in-lbs @ 90 PSIA	300 in-lbs @ 90 PSIA
Socket Speed	500 RPM	250 RPM
Horsepower	0.20 HP (0.15 kW)	0.70 HP (0.52 kW)
Air Consumption	20 SCFM	22 SCFM
Weight	2.0 lbs (0.9 kgs)	3.8 lbs (1.7 kgs)

For additional ordering information and assistance, or to order specific assembly components where applicable, please inquire.

Hi-Shear® Lever Grip Pneumatic Inst. Tooling



*20° Offset Ratchet Wrench Driver Assembly With
Multi-Length Socket And Super Key (T-Series)*

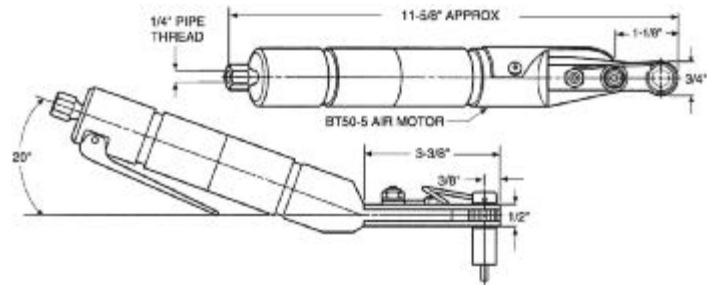

HLA2016 Available Socket Lengths						
1/2"	1"	1-1/2"	2"	3/4"	1-3/4"	4"



*Straight Ratchet Wrench Driver Assembly With
Multi-Length Socket And Super Key (T-Series)*

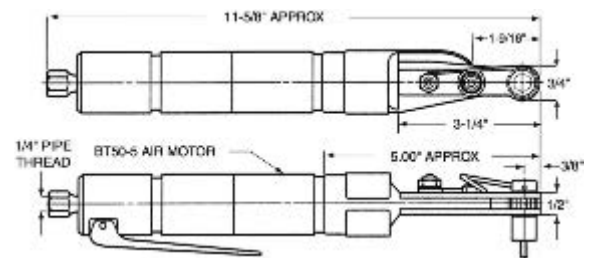

HLA2002 Available Socket Lengths						
1/2"	1"	1-1/2"	2"	3/4"	1-3/4"	4"

Specifications		
Tool	HLA2016	HLA2002
Operating Pressure	90 PSIA	90 PSIA
Max. Torque Rating	110 in-lbs @ 90 PSIA	110 in-lbs @ 90 PSIA
Socket Speed	250 RPM	250 RPM
Horsepower	0.50 (0.35 kW)	0.50 HP (0.35 kW)
Air Consumption	22 SCFM	22 SCFM
Weight	2.0 lbs (0.9 kgs)	2.0 lbs (0.9 kgs)

For additional ordering information and assistance, or to order specific assembly components where applicable, please inquire.

USATCO Hi-Shear® Tooling

USATCO offers a full selection of Hi-Shear® pneumatic tools and accessories that are too numerous to list here. If you don't see what you are looking for please contact us for assistance.